

**Series 6, free-standing freezer, 186.2 x 59.5 cm, Brushed steel anti-fingerprint GSN36AICM**



**Included accessories**

1 x ice cube tray

**Optional accessories**

KSZ39AL10 Connection set for EOH inox and PIL

**The freestanding freezer with Total No Frost for no more manual defrosting, spacious capacity, quiet operation, flexible door trays and Easy Opening Handle.**

- **XXL capacity:** our biggest Single Door capacity ever with much more space inside.
- **Total No Frost:** you won't have to defrost your freezer again.
- **Metal backwall:** stylish design with durable quality and easy cleaning.
- **Side-by-Side combination:** place a fridge next to a freezer for convenient storage.
- **Flex Door:** individually set up your adjustable door trays to organise your frozen food.

**Technical Data**

Energy Efficiency Class (Regulation (EU) 2017/1369): ..... C  
 Average annual energy consumption in kilowatt hour per year (kWh/a) (EU) 2017/1369: ..... 171 kWh/annum  
 Sum of volume of frozen compartments (EU 2017/1369): ..... 334 l  
 Airborne acoustical noise emissions (EU 2017/1369): ....35 dB(A) re 1pW  
 Airborne acoustical noise emission class (EU 2017/1369): ..... B  
 Built-in / Free-standing: ..... Free-standing  
 Frost free system: ..... Fridge and freezer  
 Width of the appliance: ..... 595 mm  
 Depth of the product: ..... 663 mm  
 Dimensions of the packed product (HxWxD): .....1930x660x760 mm  
 Warning signal / malfunction: ..... Both visual and audible  
 Cover door installation system: .....Not applicable  
 Number of drawers/baskets (Stck): ..... 4  
 Number of freezing flaps (Stck): ..... 0  
 Lockable door: ..... No  
 Thermometer freeze section: ..... Not applicable  
 Length electrical supply cord: ..... 240 cm  
 Door hinge: ..... Right reversible  
 Net weight: ..... 80.3 kg  
 Gross weight: ..... 86.5 kg  
 Multi-Flow Air Tower: ..... No  
 Economy setting: ..... Yes  
 : ..... Yes  
 Door bin adjustability - Freezer: ..... No  
 Tilt-out door bins in freezer: ..... No  
 Door bin adjustability - Freezer: ..... No  
 Reversible Door Hinge: ..... Yes  
 Frequency: ..... 50 Hz  
 Installation typology: ..... Freestanding  
 Energy Star Qualified: .....No  
 Plug type: ..... Gardy plug w/ earthing  
 Required cutout/niche size for installation (in): .....x  
 Dimensions of the packed product: ..... 75.98 x 25.98 x 29.92  
 Net weight: ..... 177.000 lbs  
 Gross weight: ..... 191.000 lbs  
 Included accessories: ..... 1 x ice cube tray



**Series 6, free-standing freezer, 186.2  
x 59.5 cm, Brushed steel  
anti-fingerprint  
GSN36AICM**

**The freestanding freezer with Total No  
Frost for no more manual defrosting,  
spacious capacity, quiet operation,  
flexible door trays and Easy Opening  
Handle.**

---

**Performance and consumption**

- Energy Class EU19\_EEK\_D: C
- Annual Energy Consumption: EU19\_Annual energy cons rd\_D: 171 kWh/a
- Climate class: EU19\_Climate class\_D: SN-T
- Fast freeze facility: yes
- Noise level: EU19\_Noise emission\_D: 35 dB

**Design**

- door external material: inox look premium
- casing color: pearl grey matt
- door handle w. easy opening: yes
- light, softstart GS
- light freezer,top
- material backwall in freezer: Glossy white

**Comfort and Safety**

- Home Connect Ecosystem
- full no frost
- MultiAirflow
- flex door
- mode, sabbath: yes
- mode, economy: yes
- number of temperatur zones: 1
- display type: 7 Segment
- door alarm freezer
- mode, super freeze: manual activating
- 90°door opening drawer removal
- side-by-side capable : can be placed alongside

**Freezer Section**

- Net Freezer Volume:
- EU19\_Frozen volume\_D: 334 l
- Freezing capacity 24h: EU19\_Freezing capa. in 24h\_D: 16 kg
- Temperature rise time : 14 H
- drawer FR,small,full,no.: 4
- Big Box: 1
- glass shelf RF,full,no.: 3

**Dimensions**

- Appliance Dimensions (H x W x D): 1862 mm x 595 mm x 663 mm

**Technical Information**

- nominal voltage min: 220 V - nominal voltage max: 240 V
- length of mains cable in mm: 2400 mm

**Series 6, free-standing freezer, 186.2  
x 59.5 cm, Brushed steel  
anti-fingerprint  
GSN36AICM**

Measurements in mm

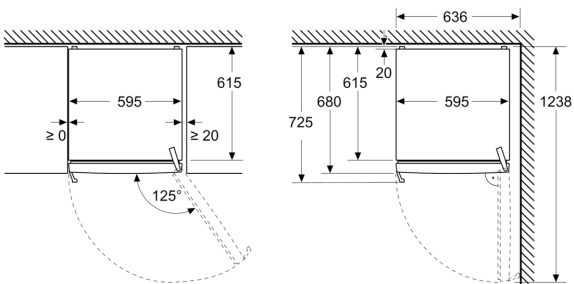

Measurements in mm

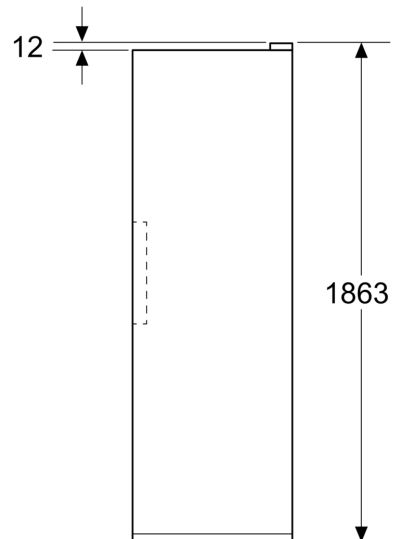

Measurements in mm

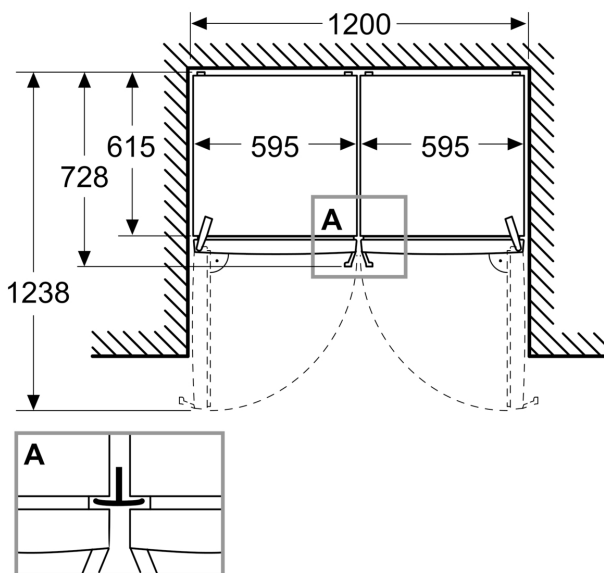

A: Air outlet  $\geq 200 \text{ cm}^2$

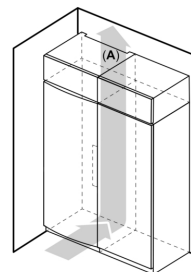

B: Air outlet  $\geq 200 \text{ cm}^2$

