

Series 4, free-standing freezer, 186.2 x 59.5 cm, Brushed steel anti-fingerprint GSN36VIDG



Included accessories

1 x ice cube tray

Optional accessories

KSZ39AL00 Connection set inox

The freestanding freezer with Total No Frost for no more manual defrosting, spacious capacity, quiet operation, and flexible door trays to fit tall containers.

- **XXL capacity:** our biggest Single Door capacity ever with much more space inside.
- **Noise Class B (30-35 dB):** enjoy the quietness for a relaxed home atmosphere.
- **Glossy white backwall:** clean, bright design with easy-to-clean durability.
- **Side-by-Side combination:** place a fridge next to a freezer for convenient storage.
- **Keep your groceries in perfect view.**

Technical Data

Energy Efficiency Class (Regulation (EU) 2017/1369):	D
Average annual energy consumption in kilowatt hour per year (kWh/a) (EU) 2017/1369:	214 kWh/annum
Sum of volume of frozen compartments (EU 2017/1369):	334 l
Airborne acoustical noise emissions (EU 2017/1369):	35 dB(A) re 1pW
Airborne acoustical noise emission class (EU 2017/1369):	B
Built-in / Free-standing:	Free-standing
Frost free system:	Fridge and freezer
Width of the appliance:	595 mm
Depth of the product:	663 mm
Dimensions of the packed product (HxWxD):	1930x660x760 mm
Warning signal / malfunction:	Both visual and audible
Cover door installation system:	Not applicable
Number of drawers/baskets (Stck):	4
Number of freezing flaps (Stck):	0
Lockable door:	No
Thermometer freeze section:	Not applicable
Length electrical supply cord:	240 cm
Door hinge:	Right reversible
Net weight:	63.2 kg
Gross weight:	69.4 kg
Multi-Flow Air Tower:	No
Economy setting:	Yes
:	Yes
Door bin adjustability - Freezer:	No
Tilt-out door bins in freezer:	No
Door bin adjustability - Freezer:	No
Reversible Door Hinge:	Yes
Frequency:	50 Hz
Installation typology:	Freestanding
Energy Star Qualified:	No
Plug type:	Gardy plug w/ earthing
Required cutout/niche size for installation (in):	x
Dimensions of the packed product:	75.98 x 25.98 x 29.92
Net weight:	139.000 lbs
Gross weight:	153.000 lbs
Included accessories:	1 x ice cube tray



**Series 4, free-standing freezer, 186.2
x 59.5 cm, Brushed steel
anti-fingerprint
GSN36VIDG**

**The freestanding freezer with Total No
Frost for no more manual defrosting,
spacious capacity, quiet operation, and
flexible door trays to fit tall containers.**

Performance and consumption

- Energy Class EU19_EEK_D: D
- Annual Energy Consumption: EU19_Annual energy cons rd_D: 214 kWh/a
- Climate class: EU19_Climate class_D: SN-T
- Fast freeze facility: yes
- Noise level: EU19_Noise emission_D: 35 dB

Design

- door external material: inox look premium
- casing color: pearl grey matt
- light, softstart GS
- light freezer,top
- material backwall in freezer: Glossy white

Comfort and Safety

- Home Connect Ecosystem
- full no frost
- MultiAirflow
- flex door
- mode, sabbath: yes
- mode, economy: yes
- number of temperatur zones: 1
- display type: 7 Segment
- door alarm freezer
- mode, super freeze: manual activating
- 90°door opening drawer removal
- side-by-side capable : can be placed alongside

Freezer Section

- Net Freezer Volume:
- EU19_Frozen volume_D: 334 l
- Freezing capacity 24h: EU19_Freezing capa. in 24h_D: 15.5 kg
- Temperature rise time : 12 H
- glass shelf RF,full,no.: 3
- drawer FR,small,full,no.: 4
- Big Box: 1

Dimensions

- Appliance Dimensions (H x W x D): 1862 mm x 595 mm x 663 mm

Technical Information

- nominal voltage min: 220 V - nominal voltage max: 240 V

Accessories

- num of ice cube trays w/o lid: 1 PC

**Series 4, free-standing freezer, 186.2
x 59.5 cm, Brushed steel
anti-fingerprint
GSN36VIDG**

Measurements in mm

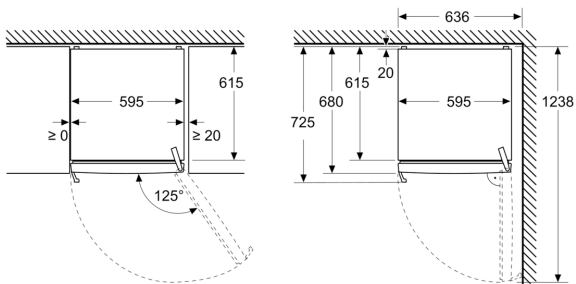

Measurements in mm



Measurements in mm

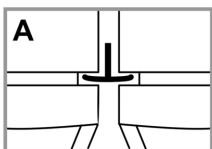
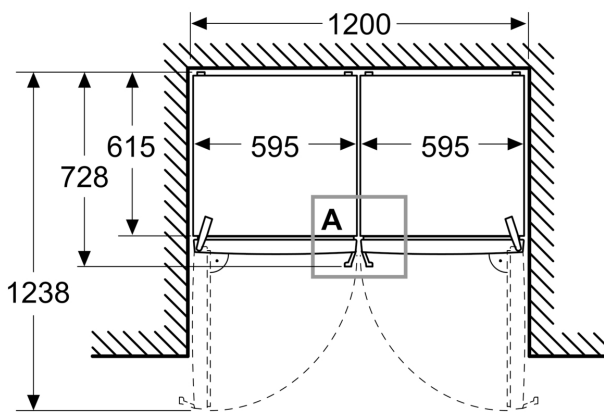

A: Air outlet $\geq 200 \text{ cm}^2$

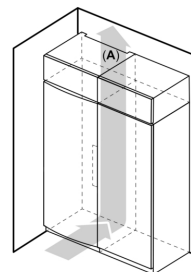

B: Air outlet $\geq 200 \text{ cm}^2$

