

**iQ500, free-standing
fridge-freezer with freezer at
bottom, 203 x 70 cm, Brushed
black steel anti-fingerprint, Total
noFrost
KG49N4XAF**



The extra-wide 70 cm Bottom freezer with hyperFresh system to keep fruit and vegetables fresh for longer, plus noFrost for no more defrosting

- ✓ Metal backwall with multiAirflow: Evenly cooled food and drinks on all levels.
- ✓ freezerLight: Clever freezer illumination.
- ✓ bottleCooler – Chills and stores your bottled drinks perfectly.
- ✓ Total noFrost: Never defrost your freezer again and bid farewell to water drops on the fridge backwall.
- ✓ doorAlarm: Reminds you to close the door and keep the cold inside.

Features

Technical Data

Energy Efficiency Class (Regulation (EU) 2017/1369):A
Average annual energy consumption in kilowatt hour per year (kWh/a) (EU) 2017/1369: 122 kWh/annum
Sum of volume of frozen compartments (EU 2017/1369): 129 l
Sum of volume of chill- and unfrozen compartments (EU 2017/1369): 311 l
Airborne acoustical noise emissions (EU 2017/1369):	...29 dB(A) re 1pW
Airborne acoustical noise emission class (EU 2017/1369): A
Built-in / Free-standing: Free-standing
Number of compressors: 1
Number of independent cooling systems: 2
Width of the appliance: 700 mm
Height: 2030 mm
Depth of the product: 667 mm
Net weight: 107.9 kg
Door panel options:Not possible
Door hinge:Right reversible
Number of Adjustable Shelves in fridge compartment: 3
Shelves for Bottles:Yes
Frost free system:Fridge
Interior ventilator: No
Reversible Door Hinge: Yes
Length electrical supply cord: 226 cm
Noise level:29 dB(A) re 1pW
Multi-Flow Air Tower: Yes
Fast cooling switch: Yes
: Yes
Temperature Controlled Drawer:No
Humidity Control Drawer: No
Number of Door Bins - Refrigerator:3
Door bin adjustability - Refrigerator:Yes
Tilt-out door bins in fridge: No
Gallon Storage:Yes
Number of Gallon storage: 1
Motorized Shelf: No
Material of the shelves: Safety glass
Door opened indicator freezer: No
Automatic motor-driven ice-maker: No
Fuse protection: 10 A
Voltage:220-240 V
Frequency:50 Hz
Storage Period in Event of Power Failure (h): 24 h
Door panel options:Not possible
Noise level:29 dB(A) re 1pW
Energy Star Qualified: No
Required cutout/niche size for installation (in): x 1

Dimensions of the packed product: 82.48 x 29.92 x 30.70
Net weight: 238.000 lbs
Gross weight: 253.000 lbs



iQ500, free-standing fridge-freezer with freezer at bottom, 203 x 70 cm, Brushed black steel anti-fingerprint, Total noFrost KG49N4XAF

Features

- Bottom Freezer, 203 cm
- black inox-antifingerprint Doors

Performance and consumption

- Energy Class EU19_EEK_D: A
- Total Volume : 440 l
- Annual Energy Consumption: EU19_Annual energy cons rd_D: 122 kWh/a
- Noise level: EU19_Noise emission_D: 29 dB

Design

- Doors black inox-antifingerprint, side panels cast iron
- Integrated vertical handle
- SoftStart LED light in fridge section

Comfort and Safety

- noFrost - no need to for manual defrosting - never again defrosting!
- Metal backwall
- Display: Twin LED electronic control
- Two Cooling Systems
- Super cool function
- Optical and acoustic door open warning system
- Optical and acoustic warning system for malfunction of freezer compartment

Fridge Section

- EU19_Unfrozen volume_D: 311 l
- multiAirflow-System
- 5 safety glass shelves of which 3 are height adjustable
- Bottle rack: Bottle cooler, Bottle grid
- 3 door bins, there of 1x dairy compartment
- No. of door cont. w/ flap door: 1 PC
- 1 door shelf large, 2 door shelf small

Freshness System

- hyperFresh

Freezer Section

- Net Freezer Volume:
- EU19_Frozen volume_D: 129 l
- Freezing capacity 24h:
- EU19_Freezing capa. in 24h_D: 11.5 kg
- Temperature rise time : 24 H
- Fast freeze facility: yes
- 3 transparent freezer drawers

Dimensions

- Dimensions (H x W x D): 203.0 cm x 70.0 cm x 66.7 cm

Technical Information

- Door right hinged, reversible hinging
- Height adjustable front feet, rolls in the back
- Length of power cord:226 cm
- Nominal voltage: 220 - 240 V
- Climate class: EU19_Climate class_D: SN-T

Accessories

- 1 x ice cube tray

iQ500, free-standing
fridge-freezer with freezer at
bottom, 203 x 70 cm, Brushed
black steel anti-fingerprint, Total
noFrost
KG49N4XAF

Dimensioned drawings

Measurements in mm

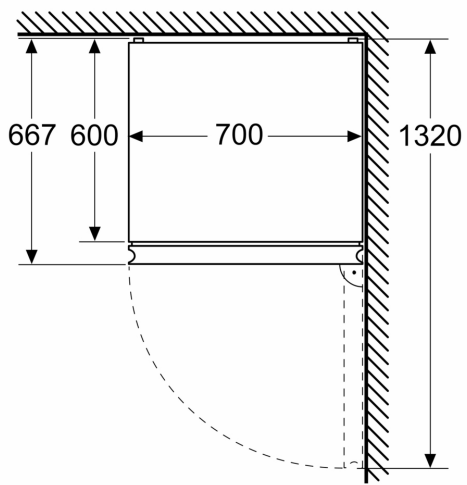

Measurements in mm

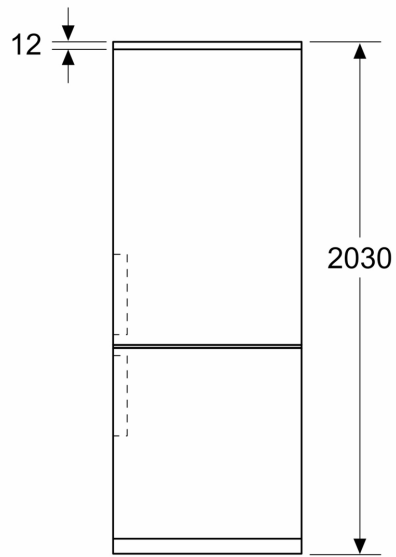

Measurements in mm

